

# sismat

**RELIABLE WATER TRANSFER AT HIGH FLOW**

**Screw Pumps**





# RELIABLE WATER TRANSFER AT HIGH FLOW

Screw pumps lift high volumes of water to the requested level. They offer the most economical and reliable solution where there is an intensive content of solid wastes at high flow. With no need for continuous operation, the systems can be activated automatically by signals from the level sensors or by time control.





### Areas of Use

- Treatment plants
- Pump stations
- Active sludge back rotate lines

### Advantages

- Simple design, strong body structure
- Reliable operation that requires little maintenance
- High efficiency
- Long life



**sismat**

# RELIABLE WATER TRANSFER AT HIGH FLOW





## Specifications

- There are 1-3 wings on screws
- Mounting angle is approximately  $30^\circ$
- Pumping height is approximately half the height of the screw and can reach 10m at maximum
- Rotation speed is between 28-80 d/d
- Nominal flow can be increased by increasing the rotary diameter and decreasing the speed.



## RELIABLE WATER TRANSFER AT HIGH FLOW

### System Components

- **Driver unit:** The reducer decreases the high speed received from the motor and the motion is transferred to the screw. The motor/reducer connection is made with a belt drive.
- **Elastic coupling:** The rotation motion and moment are transmitted by the elastic coupling from the reducer to the main shaft. It absorbs the forces caused by axial slippage that can occur between the reducer and the screw pump main shaft.
- **Upper bearing:** All the axial loads created as the screw pump transfers the water are absorbed by the upper bearing. Meanwhile, some part of the radial load is shared with the lower bearing.
- **Screw and splash plate:** The screw body that transfers the water is manufactured from spiral welded steel pipe. The steel splash plate hit by the water is mounted on one edge of the concrete trough. This plate prevents the backward movement of water and therefore facilitates the transfer.

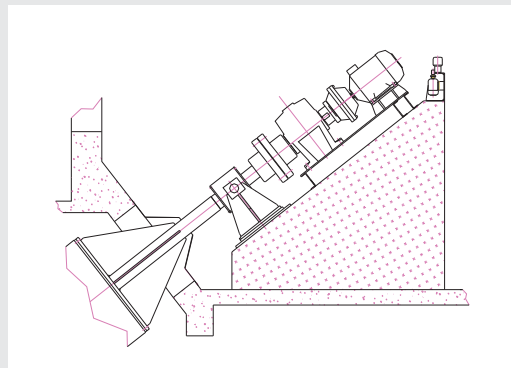
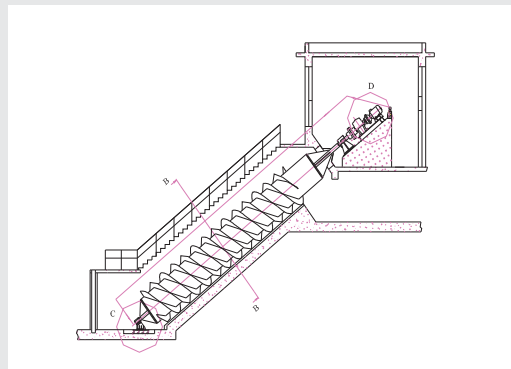

- Drive unit
- Hydraulic coupling
- Elastic coupling
- Upper bearing



- **Lower bearing:** The radial loads occurring while the screw pump transfers the water are shared by upper and lower bearings. Gaskets are used to prevent wastewater entering the bearing housing.
- **Hydraulic coupling group:** It is used to transfer the motion from the motor to the reducer. One of the biggest advantages is the softening of the motion at take off.
- **Lower bearing lubrication pump:** The grease tank and pump are found in the control room. The grease is pumped to the lower bearing through a pipe.
- **Level sensor:** Screw pumps operate when the level rises and stop when it drops.
- **Electric control panel:** The control panel designed for the operation of the pumps can operate either automatically or manually.

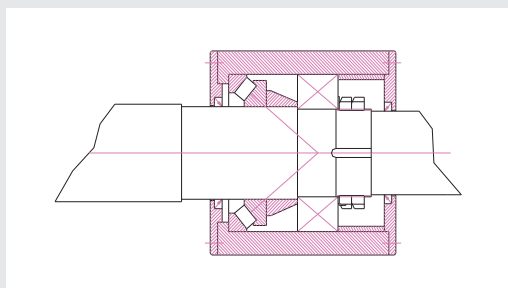

- Elastic coupling

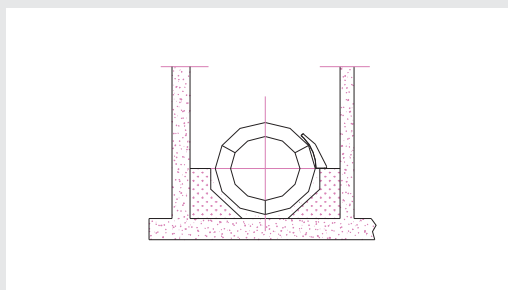

- Screw and splash plate

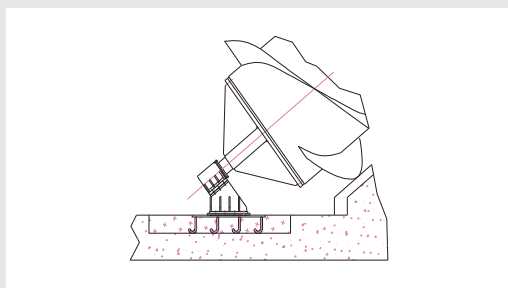

- Lower bearing

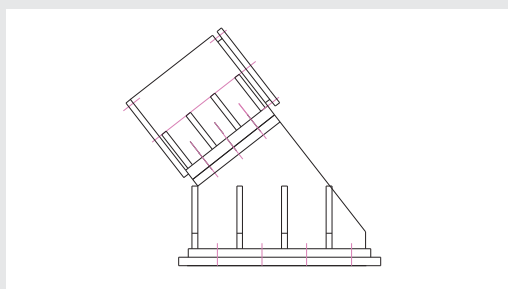

- Lower bearing

### PRE-TREATMENT EQUIPMENT

- Screens
- Screening Compactor
- Grit Classifier

### TREATMENT EQUIPMENT

- Screw Pump
- Surface Aerators
- Scrapers
- Thickeners
- Flow Control Devices

### DEWATERING EQUIPMENT

- Pre-dewatering Belt
- Beltpresses
- Filterpresses
- Chemical Preparation and Dosing Units

### PACKAGE TYPE BIOLOGICAL TREATMENT PLANT

- BIOPAK

### FILTRATION UNITS

- Pressure Sand Filter
- Ion Exchanger
- Activated Carbon Filter

### OTHERS

- Screw Conveyor
- Belt Conveyor
- Double Shaft Mixer
- Container Station
- Oil and Grease Separators

## SİSMAT ULUSLARARASI ARITMA MAKİNALARI İNŞAAT MÜHENDİSLİK SAN. VE TİC. LTD. ŞTİ.

Gebze Organize Sanayi Bölgesi,  
İhsan Dede Cad. 800. Sk. No: 802  
Gebze 41480, Kocaeli/Turkey

Tel : +90 262 751 12 54  
Fax : +90 262 751 12 56  
info@sismat.com.tr

[www.sismat.com.tr](http://www.sismat.com.tr)