

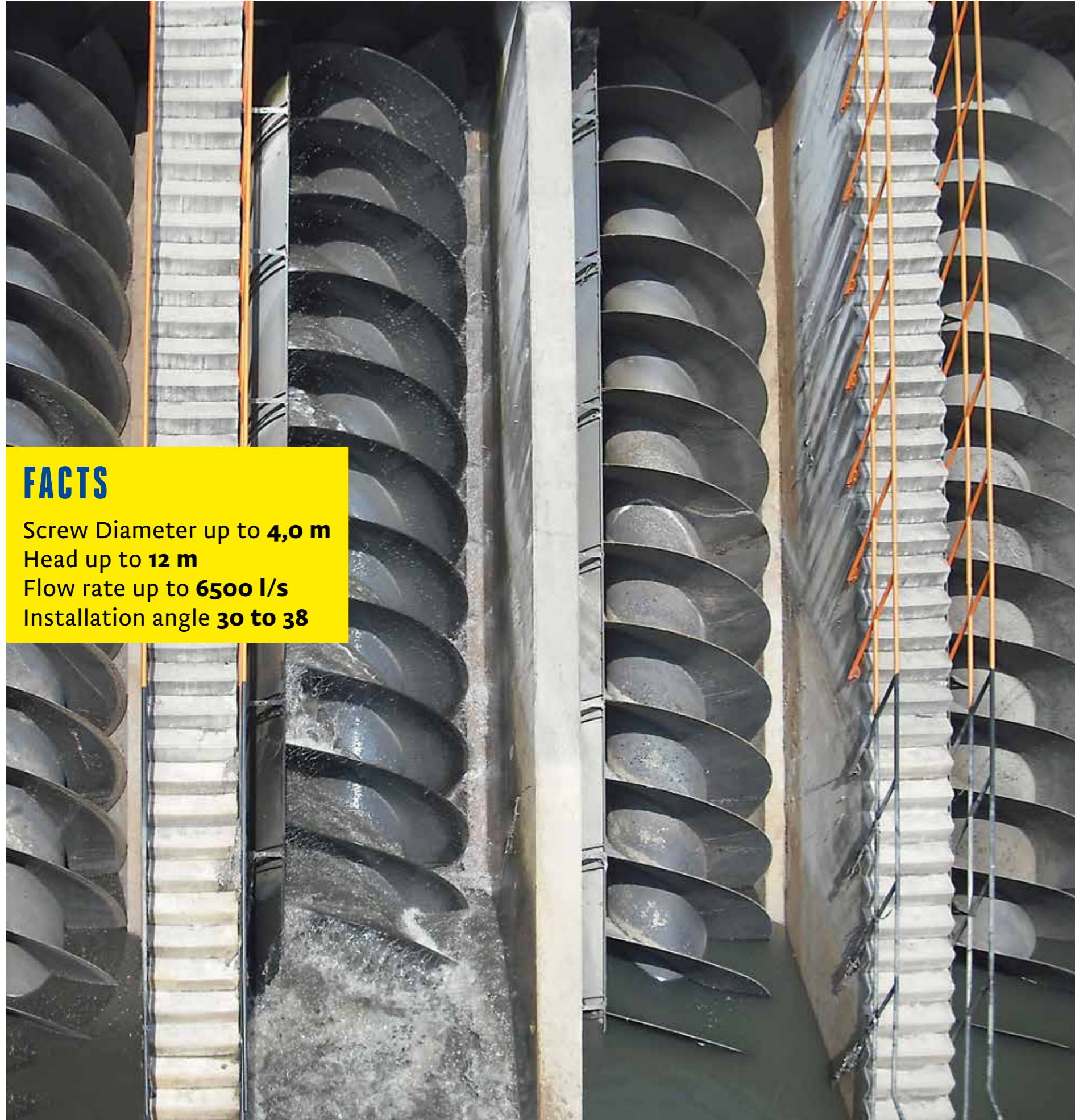

Sismat Uluslararası
Arıtma Makinaları
İnşaat Mühendislik
Sanayi ve Tic. A.Ş.



**ARCHIMEDIAN
SCREW PUMPS**



FACTS

Screw Diameter up to **4,0 m**
Head up to **12 m**
Flow rate up to **6500 l/s**
Installation angle **30 to 38**

ARCHIMEDIAN SCREW PUMPS TO TRANSFER WATER

Sismat Uluslararası screw pumps are equipment used to lift water to the requested level in treatment plants or pumping stations. It requires little maintenance due to its simple design, strong body structure, transfer screw which is resistant to erosion and reducer which can overcome all the loading. It can easily transfer big particles as well.

Screw pumps can be operated in different ways according to their purpose of use. The screw which provides the transport is the only part of equipment that is driven. It does not need to operate continuously. Its automatic operation can be provided generally by level sensors.

FEATURES AND BENEFITS OF SISMAT ULUSLARARASI SCREW PUMPS:

- Wide range of applications,
- Robust, reliable and very long life-cycle,
- Low maintenance and operation costs,
- Minimum risk of clogging,
- Simple solution with high durability,
- Very economical,
- Automatic adjustment to feed flow, performance range variability.

MAIN AREAS OF USE

- Treatment plants
- Hydropower plants
- Polder drainage
- Irrigation systems
- Rivers
- Cooling water outlets
- Industrial process industry
- Return sludge transport

Typical Screw Pump & its Components

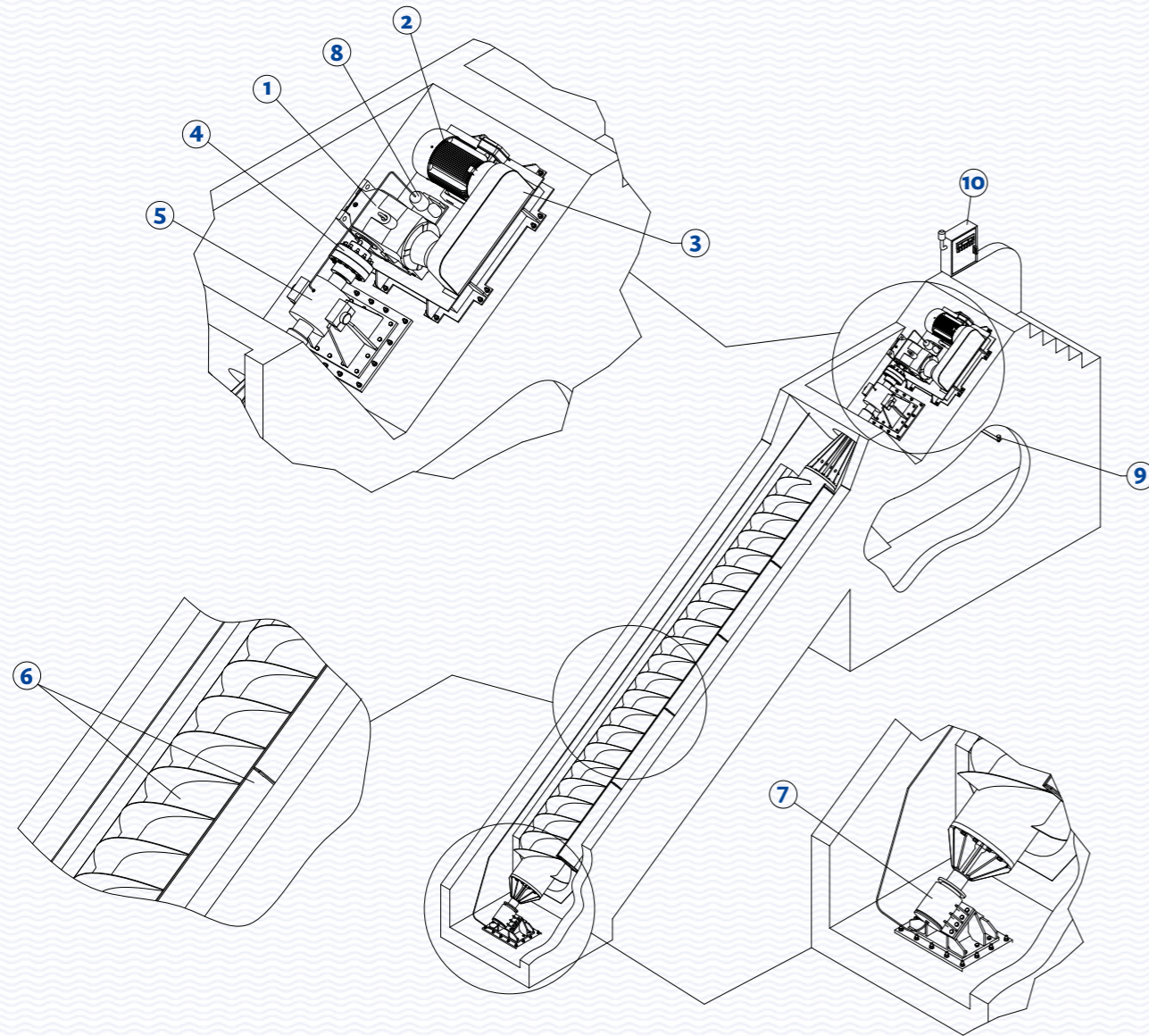

| Screw Pump Components | |
|-----------------------|---------------------|
| 1 | Reducer |
| 2 | Motor |
| 3 | Belt Coupling Group |
| 4 | Elastic Coupling |
| 5 | Upper Bearing |

| Screw Pump Components | |
|-----------------------|--------------------------------|
| 6 | Screw and Splash Plate |
| 7 | Lower Bearing |
| 8 | Lower Bearing Lubrication Pump |
| 9 | Level Switches |
| 10 | Electrical Control Panel |

1. REDUCER

High speed received from the motor is decreased by the reducer and the motion is transferred to the screw. The reducer is totally enclosed. All the gears operate inside the oil bath. The direction of rotation is very important for the reducers' of the screw pumps. The screw pump that rotates in reverse direction does not transfer water. While the screw pump is transferring water, if it suddenly stops, the water remained among the flights rotates the pump in reverse direction. This is an unwanted situation. For that reason, a backstop has to be used inside the reducer.

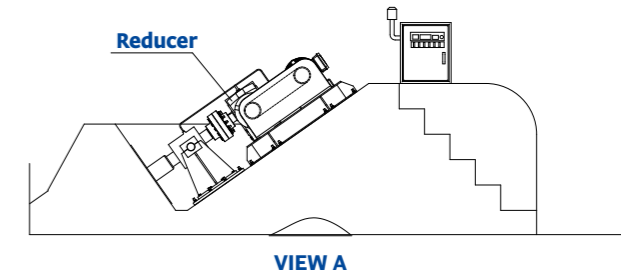
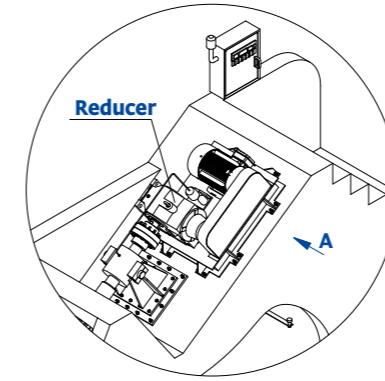

2. MOTOR

It is asynchronous type and short circuit. Its cooling is provided by impeller.

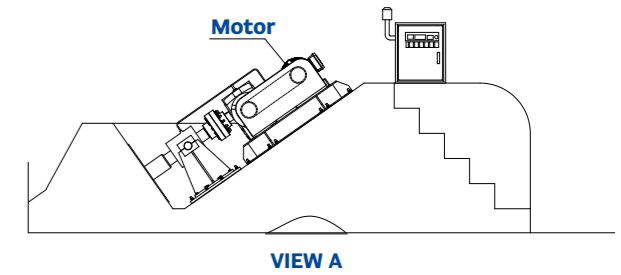
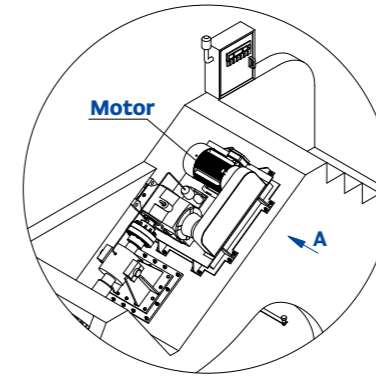

3. BELT COUPLING

A belt coupling is used to transfer the motion from the motor to the reducer. A few of the biggest advantages of the belt drives is simple and economical, noise and vibration are damped out. Machinery life is increased because load fluctuations are shock-absorbed

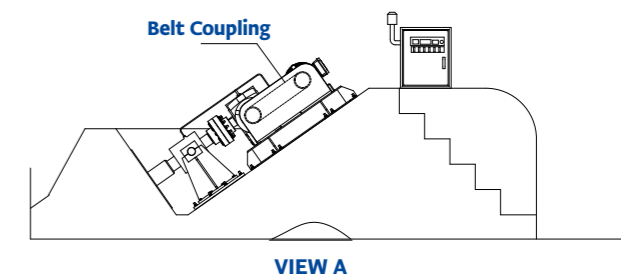
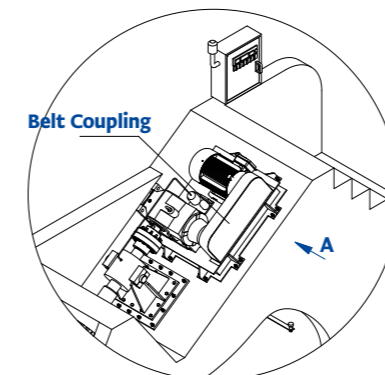

4. ELASTIC COUPLING

The rotation motion and moment are transferred by elastic coupling from the reducer output spindle. Special formed, resistant to erosion elastic couplings are used.

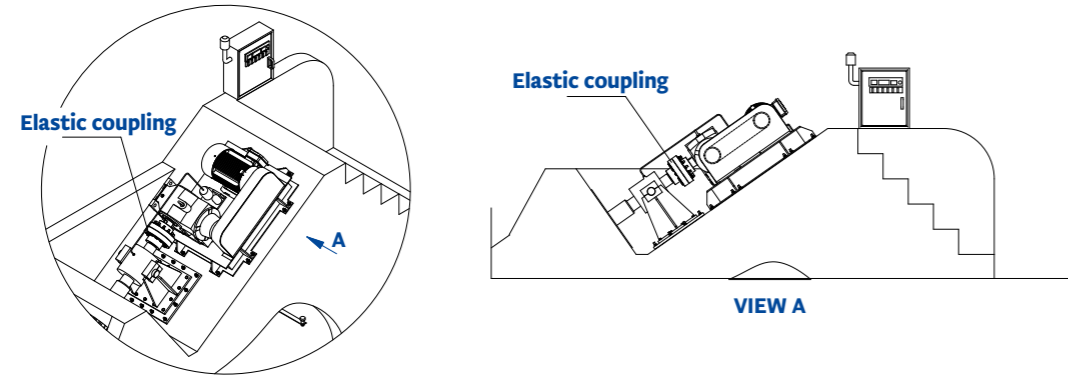

5. UPPER BEARING

All the axial loading occurred while the screw pump is transferring water is overcome by upper bearing. Meanwhile, some part of the radial loading shared with lower bearing is overcome by upper bearing.

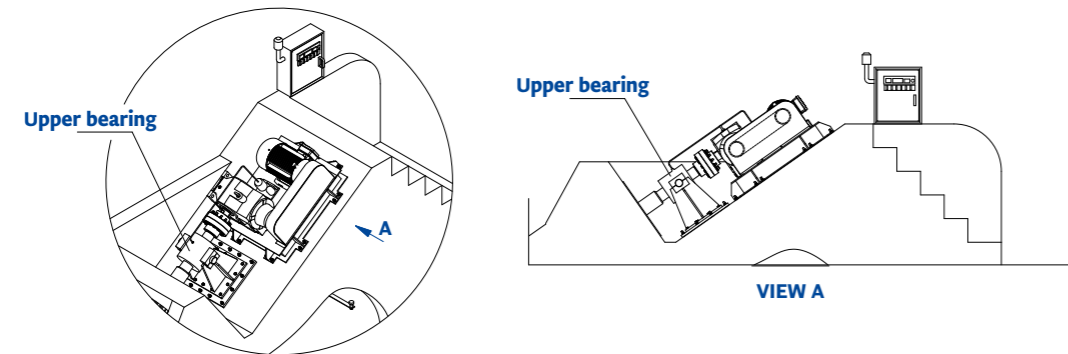

6. SCREW AND SPLASH PLATE

The screw body that transfers the water is manufactured from the spiral welded steel pipe. The screw flights are welded vertically to the frame by the center passed light principle. During water transferring, a steel splash plate is mounted at the end of concrete through. This plate prevents backward movement of water and therefore, facilitates the transfer.

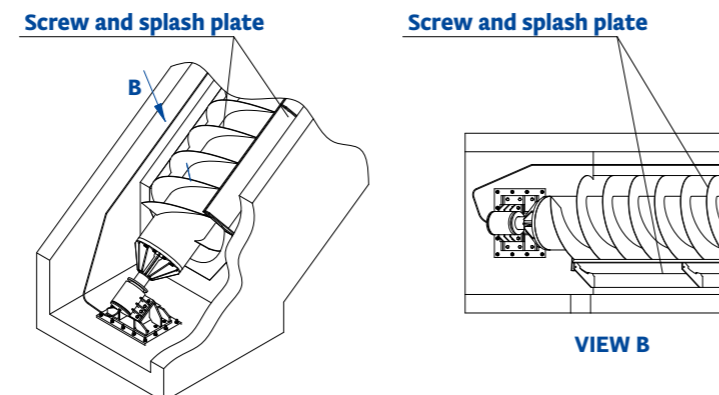

7. LOWER BEARING

The radial loading occurred while the screw pump is transferring water is shared by upper and lower bearings. The lower bearing is manufactured from bronze material. The frame of it is steel. The lubrication of lower bearing is done compulsorily. Gaskets are used to prevent wastewater entering the bearing housing.

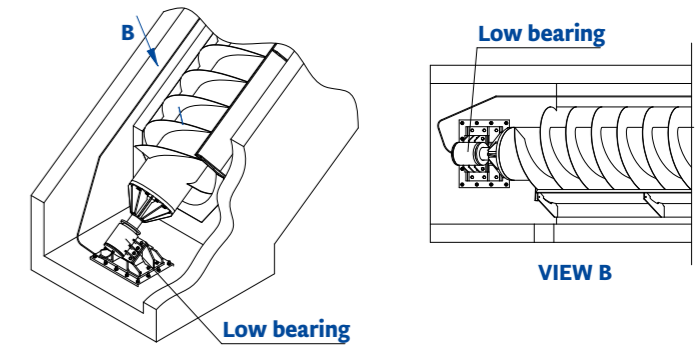

8. LOWER BEARING LUBRICATION PUMP

It consists of a tank having an equal volume with grease and a motor that drives the tank. The pressed grease is transferred to the lower bearing by a pipe.

Lower bearing lubrication pump

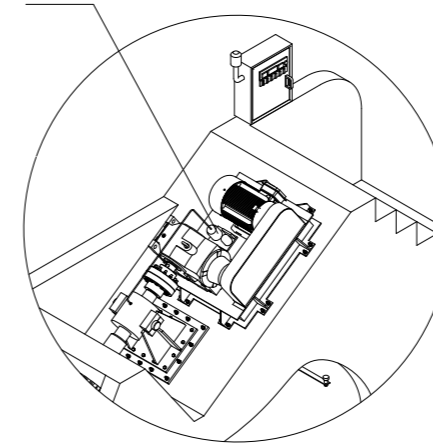

9. LEVEL SENSORS

The screw pumps operate when the level increases and stop when drops.

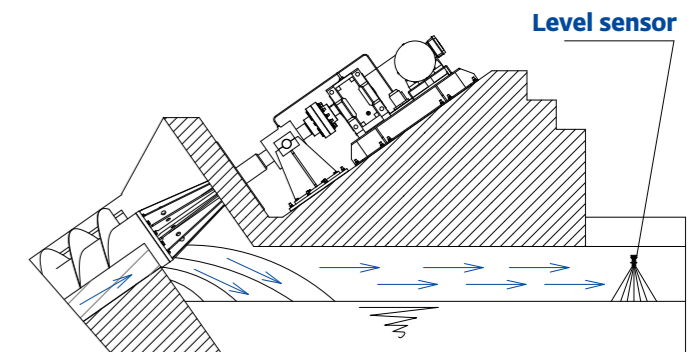

10. ELECTRICAL CONTROL PANEL

The control panel which is designed for operation of the pumps can operate either automatically or manually.

Electrical control panel

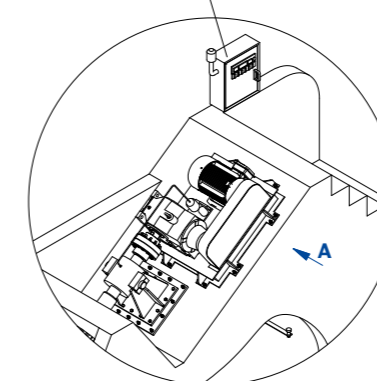

Electrical control panel

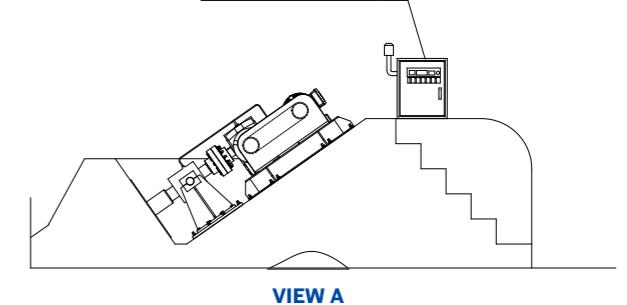

SCREW PUMP TYPES

SCREW PUMPS IN A CONCRETE TROUGH

This is the most common arrangement for screw pumps where screw pump is placed in an open concrete trough, where the screw rotates in the trough with a gap of only a few millimeters. The trough is formed by the help of the slowly rotating screw, which is provided temporarily with a metal strip; while soft concrete is poured into the trough, the screw forms a good trough shape fitting the screw.

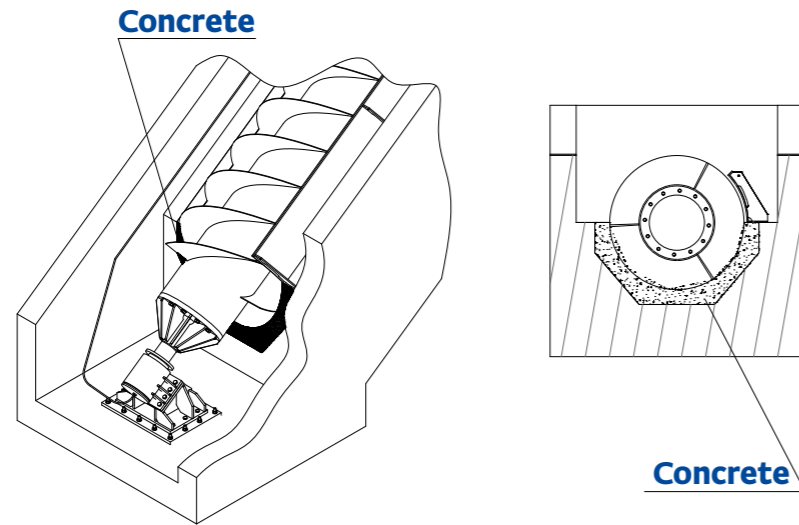

SCREW PUMPS WITH A STEEL TROUGH LINER

Instead of screeding, a prefabricated steel trough liner is used and backfilled with concrete. A steel trough liner increases the lifetime of trough.

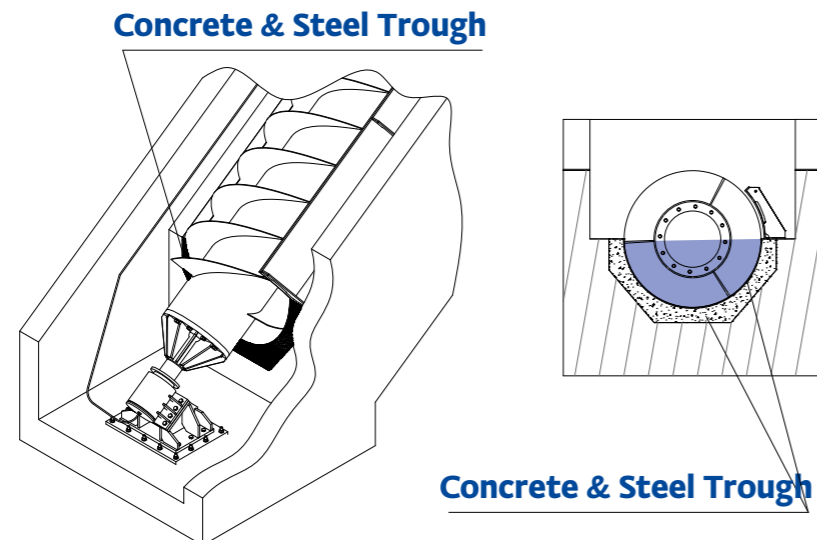

THE COMPACT PLANT

This screw pump type is pre-assembled in our factory and shipped in one piece, ready for immediate installation. The compact plant can be manufactured with an enclosed or open steel trough. This type has a self-supporting trough with integrated drive unit.

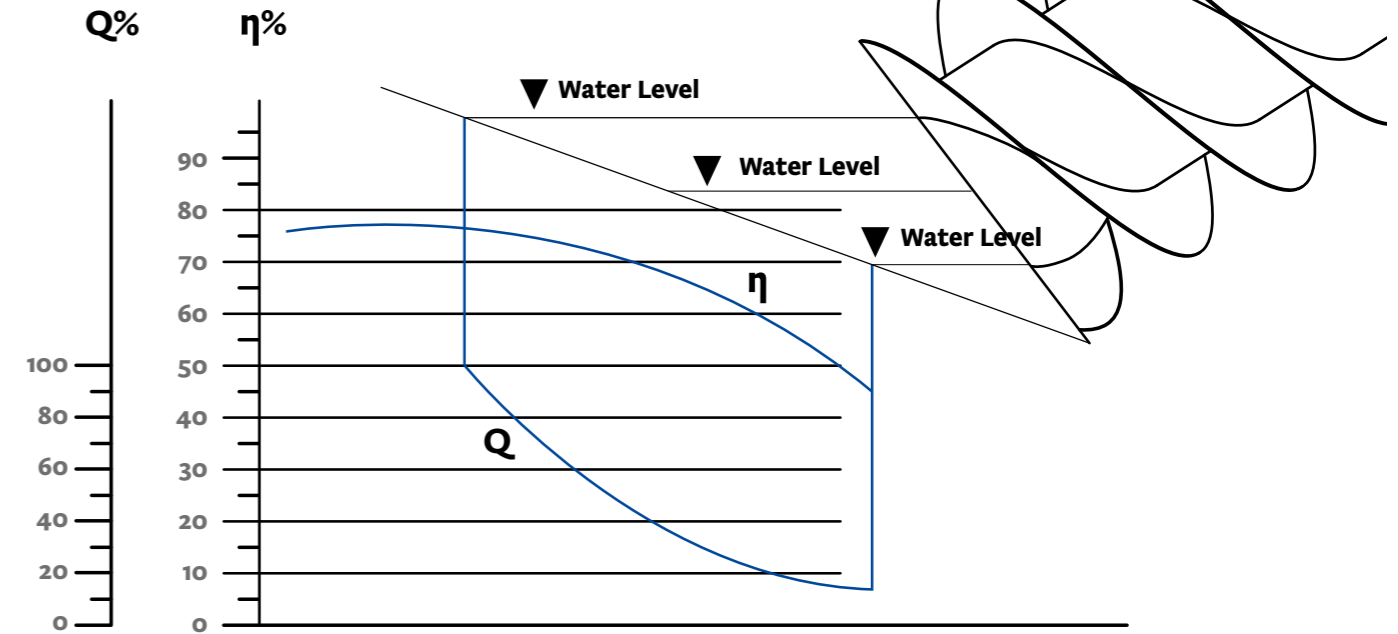

Screw Pump Capacity and Efficiency
The graph illustrates the ratio between influent height, pump capacity (Q) and efficiency (η)

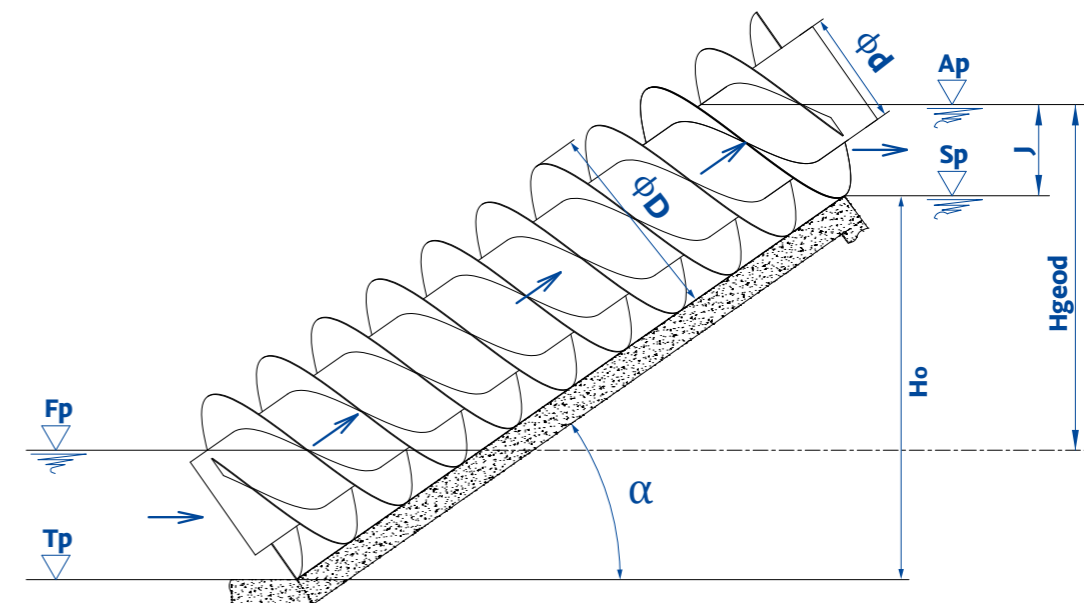

FP: Filing point. It shows the underwater damming level at which the screw reaches its full conveying current, its highest efficiency as well as its highest power draw.

TP: Touch point. It shows the underwater water level at which the screw blade barely touches the water

level without initiating conveying.

AP: Outlet point. It is defined by the highest screw volution where the water is discharged, the water level in the outlet canal can rise while the screw is in operation without causing back-flow over the screw.

SP: Chute point. It is plunging point level.

α : Installation angle
D: Screw diameter
d: Support pipe diameter.
Ho: Constructional head
Hgeod: Geodetic conveyer height. It is the hydraulic pumping head of the pump





Learn More by visiting

www.sismat.com.tr

Sismat Uluslararası Arıtma Makinaları
İnşaat Mühendislik San. ve Tic. A. Ş.
Address: Gebze Güzeller Organize Sanayi Bölgesi (GGOSB)
Fatih Sultan Mehmet Cd. 5/1 Gebze/Kocaeli/Türkiye
Telephone : +90 262 751 12 54
Fax: +90 262 751 12 56